

REGLE GENERALE DE MONTAGE
GENERAL PRINCIPLE FOR ASSEMBLY

EMMANCHEMENT GRAS
LOOSE FITTING

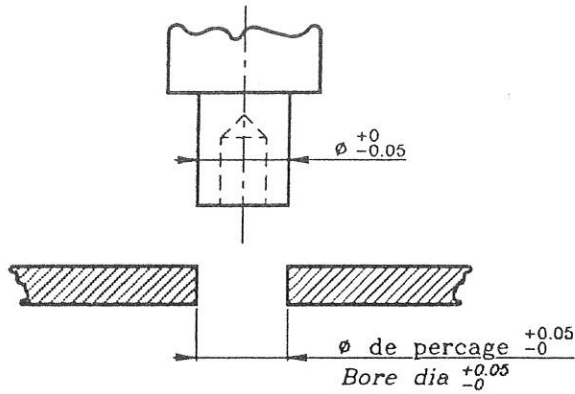

EMMANCHEMENT A FORCE
PRESS FITTING

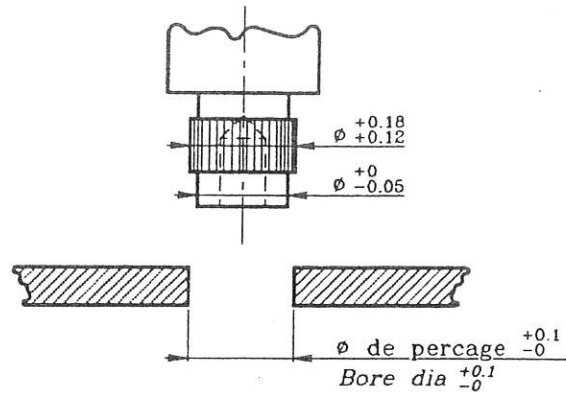

OUTIL DE MONTAGE DES PLOTS POUR C.I.
ASSEMBLY TOOL FOR P.C.B. TERMINAL PINS

COMPOSITION D'UN JEU D'OUTIL

- Trois ou quatre pièces selon le type :
- le poussoir (A, AT, B, C ou G),
 - l'embase (de 1 à 100),
 - l'adaptateur (F, L6 ou L10),
 - le sertisseur (R ou S) (voir ci-dessous).

Le sertissage est caractérisé par deux procédés :
(S).ROULE.
(R).CONIQUE.

COMPOSITION OF SET OF TOOLS

- Three or four components depending on type :
- pusher (A, AT, B, C or G),
 - receptacle (from 1 to 100),
 - adaptor (F, L6 or L10),
 - crimper (R or S) (see below).

There are two methods of crimping :
(S).ROLLED,
(R).CONICAL.

ADAPTATEURS
ADAPTERS

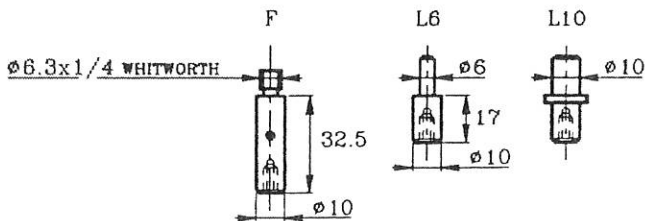

SERTISSEURS
CRIMPERS

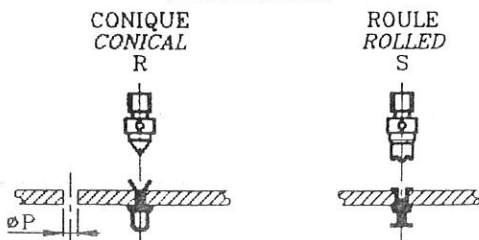

POUSOIRS
PUSHERS

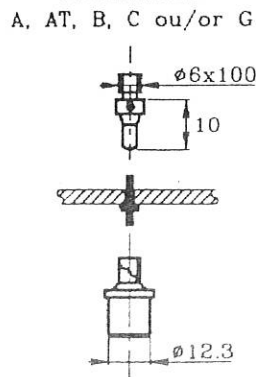

EMBASES
RECEPTACLES

DE 1 A 100
FROM 1 TO 100

